

NOTES: UNLESS OTHERWISE SPECIFIED

1	
2	ALL DIMENSIONS ARE IN MM
3	TOLERANCE :ISO 2768-1:1989

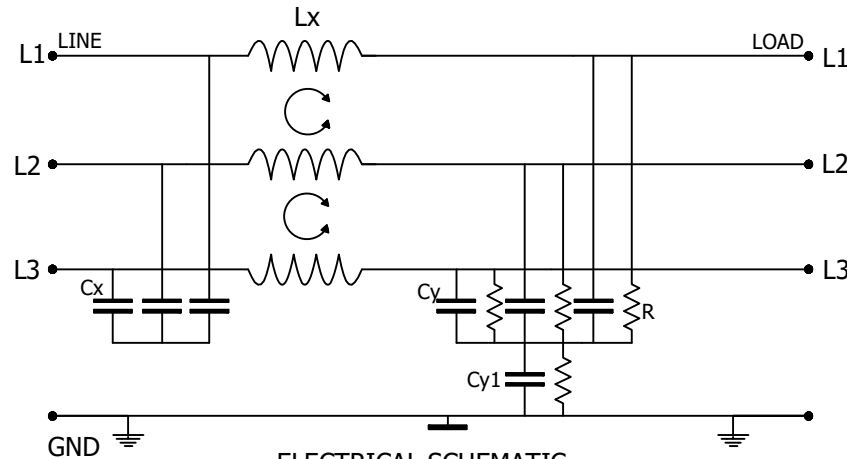

ELECTRICAL SCHEMATIC
50 ohm - 50 ohm Typical Insertion Loss

FREQUENCY MHZ	0.01	0.1	0.5	1.0	2.0	5.0	10
COMMON DB	22	58	80	72	62	50	39
DIFFERENTIAL DB	15	37	73	63	57	51	48

PRODUCT LABEL

LINE	BLA ETECH PVT.LTD.	LOAD
	BL358-100-T	
	480-520 VAC, 50-60 Hz	
	100A@40°C	
	25/100/21	

SPECIFICATION

- 1) RATED VOLTAGE (MAX):
100 AMP, 480/520 VAC 50-60HZ;
- 2) Hi-pot RATING (2 SECOND):
LINE TO GROUND: 2650 VDC
LINE TO LINE : 2100 VDC
- 3) MAXIMUM LEAKAGE LINE TO GROUND:
4.30mA @480 VAC 60 Hz;
4.70mA @520 VAC 50 Hz;

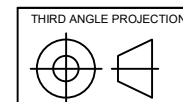

A	ISSUE	ECN	SUJIT	AJAY	20-02-2019
REV.	DESCRIPTION		DWN	APVD	APVD DATE
		BLA ETECH PVT.LTD. A-42 , Wazirpur Industrial Area New Delhi, Pin 110052 INDIA			
DRAWN BY	DRAWN DATE	CHECKED BY	CHECKED DATE		
SUJIT	20-2-2019	AJAY	20-02-2019		
DESC. MULTI STAGE FILTER					PAGE 1 of 1
PART NO. BL358-100-T					